

Complete system solutions

system

Complete system solutions

solutions

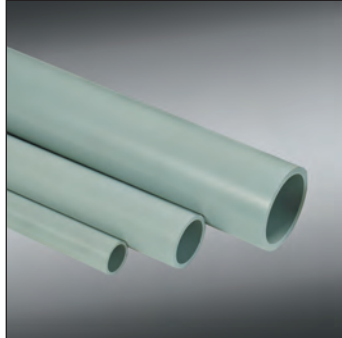
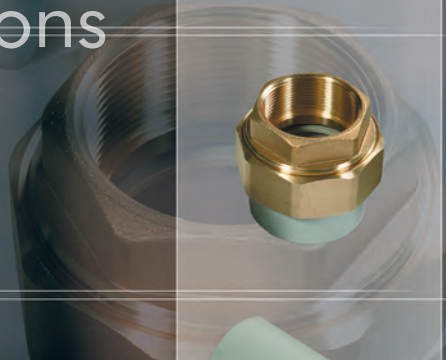

 **Durapipe**
corzan

Pipes, Fittings and Valves

Metric Systems

Complete system solutions

Technical
Data and
Dimensions



 Durapipe

Complete system solutions

At the forefront of development and manufacture of thermoplastic pipework for over half a century, Durapipe products are widely used in Utilities, Industrial and Building Services sectors around the world.



- Fully matched system
 - Wide range of manual and actuated valves
 - Comprehensive technical support
 - Fully approved
- ... don't take a chance with any other brand



Index

	page
Abbreviations.....	3
The System	4-11
Joining Procedure	12-15
General information.....	16
Dimension specifications and general notes	17
Metric/inch pipe dimensional comparison tables.....	18
Index to Durapipe Corzan fittings.....	19
Pipe (plain)	20
Sockets (plain).....	20
Reducing bush (plain)	20
Elbow 45° (plain)	21
Elbow 90° (plain)	21
Tees 90° (plain).....	21
Tees 90° (reducing)	21
Composite unions (plain/BSP threaded female brass)	22
Composite unions (plain/BSP threaded male brass)	22
Caps (plain)	22
Tees 90° (threaded/branch with reinforcing ring)	22
Socket union (plain)	23
Adaptor nipple (plain female/threaded male).....	23
Elbow 90° (plain/threaded with reinforcing ring).....	23
Adaptor socket (plain/threaded with reinforcing ring).....	23
Socket union (plain/threaded).....	24
Adaptor socket union (inch/metric plain).....	24
Flanges stub serrated	24
Backing rings (galvanised mild steel).....	25
Valve support plates (galvanised mild steel)	25
Flat gaskets.....	26
'O'-ring for socket union.....	26
Cobra pipe clips.....	26
Solvent cement and cleaner	26
Tools	27
Pipe clips.....	27
Brushes	27
VK double union ball valve (plain/female)	28
Diaphragm valves (male)	28
Diaphragm valves (pneumatic)	28
Ball check valves (male/female).....	28
Butterfly valves (manual)	29
Pressure relief valves (plain male ends)	29
RV Sediment strainer, manual – FPM seals	29
TK-PVC-C 3-way T Port Ball Valve.....	30
Actuated valves (electric and pneumatic).....	30

Abbreviations and materials

The following list of abbreviations is used in this catalogue:

ABS	– Acrylonitrile Butadiene Styrene
PVC-U	– Unplasticised Polyvinyl Chloride
PP	– Polypropylene
PVC-C	– Chlorinated Polyvinyl Chloride
CORZAN®	– PVC-C compound
CORZAN™	– Industrial Pipework by Durapipe, using CORZAN® PVC-C material
PVDF	– Polyvinylidene fluoride
EPDM	– Ethylene Propylene Rubber
FPM	– Fluorine Rubber (Viton®)
PTFE	– Polytetrafluoroethylene (e.g. Teflon®)

Viton® and Teflon® are DuPont registered trade names.
 CORZAN® and CORZAN™ are registered trade names of Noveon.

The System

Introduction

Durapipe UK has been manufacturing thermoplastic pressure pipework systems since the early 1950's. Post-chlorinated polyvinyl chloride material, PVC-C was first developed by BF Goodrich in 1958 and has always offered superior corrosion resistance, mechanical strength and excellent life-cycle economies.

Today as Durapipe Corzan it goes on providing longer service life, lower maintenance costs and reduced downtime when compared to traditional materials.

The availability of a wide range of process industry plant in Durapipe Corzan material, in addition to matched pipes fittings and valves enables engineers to take advantage of these benefits throughout entire industrial systems.

The matched system comprises a wide selection of quality pipes, fittings and valves. It is supported by Durapipe UK's own Research and Development facilities, a specialist Actuated Valve Department and a Technical Support Department with considerable experience in thermoplastic piping systems. Expert advice is always on hand on any aspect of Durapipe Corzan systems.

This user's guide serves to outline the design and installation techniques required to achieve a safe, high integrity, long lasting system.

Details that are not available in this publication can be obtained from our Technical Support Department.

Benefits

The advantages of Durapipe Corzan include:

Highest specification material – highest quality pipework

Durapipe Corzan is the registered trade name for Noveon (formerly BF Goodrich) superior quality PVC-C material. Its compounds are a mixture of PVC-C resin and additives that facilitate processing and provide the properties necessary for pipework applications.

Compared to traditional materials, it provides a longer service life, lower maintenance costs and reduced downtime. The brand name guarantees quality.

Ideal for hot corrosive chemicals

Durapipe Corzan's unbeatable balance of properties, chemical resistance, installed cost and working pressure at elevated temperature, offers high performance for many industries. When resistance to strong mineral acids, alkalis or effluent handling is required, Durapipe Corzan from Durapipe UK is the ideal choice.



Minimum life-cycle costs

Durapipe Corzan inherently has the performance required for many process applications. Corrosion resistance and mechanical strength, at a total installed cost lower than carbon steel.

Installed Cost Comparison

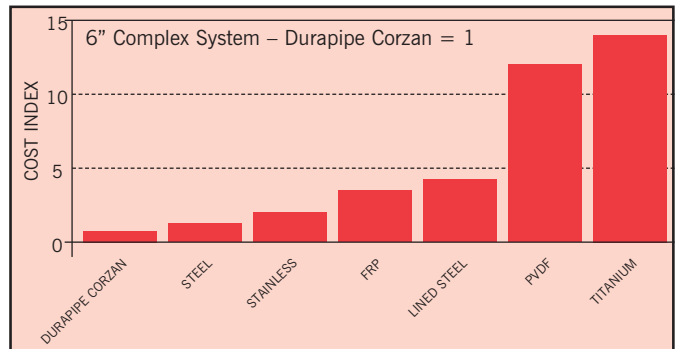

Non-toxic and taint free

The Durapipe Corzan formulation does not contain harmful metallic stabilisers. Durapipe Corzan industrial systems are suitable for potable water and are WRc listed. There is no risk of taint or contamination of the media by migration of undesirable additives. Durapipe Corzan can be used for food products, soft drinks, medical preparations, but because of the highly individual and subjective nature of tastes and aromas, thorough trials are recommended before adopting Durapipe Corzan for a foodstuff or beverage application.

Abrasion resistance

Durapipe Corzan offers good resistance to abrasion and erosion from aggressive slurries, which can rapidly damage steel or other traditional pipe materials.

Smooth bore

Low fluid friction allows higher flow velocities than in metal pipe and also inhibits the formation of scale, with consequent savings in pump energy consumption, and in reduced pressure drops.

Light weight

At half the weight of equivalent copper pipe and one-sixth the weight of steel systems, Durapipe Corzan is much easier to handle, especially during installation on site.

Easy to joint

Solvent welding gives fast and trouble free installation and allows simple modification of existing systems with the minimum specialist training.

Availability

An established network of stockholding distributors in the UK and overseas ensures that Durapipe's Corzan systems are available near the point of use.

Durapipe Corzan and the Environment

All materials and products have some effect on the environment. As a result, society must carefully weigh the environmental impact against the benefits that are derived from a particular product – an ecobalance approach.

Durapipe Corzan pipework by Durapipe UK provides many important benefits while having relatively little effect on the environment. The material's durability is the key to its favourable ecobalance, providing long-lasting, high-performance products that generate minimal solid waste.

Benefits for the user include its purity, resistance to fire, mechanical strength, wide operating temperature range, corrosion resistance and affordability.

The manufacture and use of Durapipe Corzan pipework consumes less of our non-renewable resources (oil, gas and coal) compared to other materials. Durapipe Corzan's low petroleum content, energy-efficient manufacturing process and light weight all contribute to its low energy requirements.

Durapipe Corzan does not play a significant role in any of the major environmental issues facing the world today. Throughout its entire life cycle – from manufacture and use to its eventual disposal – Durapipe Corzan pipework presents a very favourable balance, with benefits that far outweigh its environmental costs.

Durapipe UK operates an environmental management system that has been successfully assessed against the BS EN ISO 14001 environmental management standard.



Mechanical/Physical/Electrical data

General

Density	1.55g/cm ³
Water absorption	+0.03% at 23°C
Rockwell hardness	119 at 23°C

Mechanical

Ultimate tensile strength (23°C)	55MPa
Tensile strength at break	46MPa
Young's Modulus	2500MPa
Compressive strength	70MPa
Poisson's Ratio	0.35
Izod impact strength at 23°C (notched)	80J/m

Physical

Vicat B50 softening temperature (ISO 306)	110°C
Linear coefficient of thermal expansion	6.1 x 10 ⁻⁵ /°C
Heat distortion temperature	103°C
Specific heat	0.84 J/g at 23°C 1.1 J/g at 100°C

ASTM D648 using a 0.45MPa stress

Thermal Conductivity	0.137 W/m/K
----------------------	-------------

Flammability

Flame spread ASTM E84	15 (low flame spread category)
Smoke developed	70 to 125 (low smoke category)
Limiting Oxygen Index	60%

Electrical

Dielectric strength	492,000 V/cm
Dielectric constant	3.70 at 60Hz
Power factor	0.007%
Volume resistivity	3.4 x 10 ¹⁵ ohm/cm

Product range



Metric system

The Durapipe Corzan system is manufactured in accordance with the sizes detailed in DIN8079 and DIN8063 from 16mm o.d. (outside diameter) to 160mm o.d. Pipes and fittings are 16 bar rated at 20°C, except 160mm pipe which is 10 bar rated.

Connections onto other pipework in Inch (nominal bore) sizes can be made by using mm/inch adaptor fittings or by mechanical connections e.g. threaded fittings and flanges.

Male and female threads are parallel and conform to the nominal requirements of BS21/DIN299/ISO7.

Quality



Certificate No. FM 34819



Durapipe UK operates a Quality Management System which has been successfully assessed and certified to the requirements of ISO 9001, by the British Standards Institution. These standards cover all aspects of product design manufacture, inspection, storage and dispatch.

In addition to quality control tests on the product, long term investigations including long term regression analysis have been carried out on the Durapipe Corzan material, to ensure system integrity throughout the operational life of the system.

Approvals

The following organisations have approved Durapipe Corzan systems:



The following companies are all major users of Durapipe Corzan pipework systems:

- Mullards
- Seven Seas Foods
- Thermes Du Boulou
- French Army
- Monklands District General Hospital, Glasgow
- Stoke Mandeville Hospital
- St Richard's Hospital
- Claydon House National Trust Property
- Bedford Hospital
- St Monicas House Retirement Residence
- Morton Hill Farm Nursing Home
- Coast Line Hotels, Malta
- Imperial Hotel, Brighton
- Thameside Hospital, Manchester
- New Glendon Hospital, Montserrat, West Indies.

Applications

The following is a list of applications for Durapipe Corzan pipework systems:

- Acids
- Alkalis
- Cooling Water
- Demineralised Water
- Dyes
- Flocculants
- General Chemical Dosing
- Potable Water
- Pulps
- Soap Solutions
- Sterilants
- Treated Effluent
- Untreated Effluent

Typical installations include hot and cold water plumbing, metal surface treatment, pulp and paper production, chemical processing, industrial waste treatment and the food and beverage industry.

Durapipe Corzan System Design

Pressure/temperature/life relationship

1. Chart's are based on an ambient temperature of 20°C.
2. For higher ambient temperatures, decrease the working pressure by 5% for every 10°C rise above 20°C.
3. Durapipe Corzan systems should not be used at temperatures in excess of 95°C or below +5°C.

Permissible Working Pressures for pipes transporting water in accordance with DIN 8079

Contents Temp. (°C)	Design Service Life (Years)	Pressure Rating	
		PN10	PN16
20	1	11.7	18.7
	5	11.0	17.6
	10	10.7	17.1
	25	10.4	16.5
	50	10.0	16.0
30	1	10.2	16.1
	5	9.5	15.1
	10	9.2	14.6
	25	8.8	14.1
	50	8.6	13.6
40	1	8.6	13.6
	5	7.9	12.6
	10	7.7	12.2
	25	7.3	11.6
	50	7.1	11.2
50	1	7.0	11.2
	5	6.4	10.2
	10	6.1	9.8
	25	5.8	9.3
	50	5.6	8.9
60	1	5.5	8.8
	5	5.0	7.9
	10	4.7	7.5
	25	4.5	7.1
	50	4.3	6.8
70	1	4.1	6.6
	5	3.6	5.8
	10	3.5	5.5
	15	3.3	5.3
80	1	2.9	4.7
	5	2.5	4.0
85	1	2.4	3.9
	3	2.2	3.5
95	1	1.6	2.6

Chemical Resistance

For details of chemical resistance of Durapipe Corzan systems, refer to brochure D0238, Durapipe Systems Chemical Resistance Data.

Flow Calculations (see Flow Nomogram page 8)

Flow calculation for liquids.

Pressure drop due to friction can be determined for practical purposes using the flow nomogram on page 8. The nomogram is based on the Colebrook White formula for water at 10°C, using a hydraulic roughness factor of 0.003mm.

The pressure drop at a given flow rate can be determined as follows:

1. Obtain the mean bore diameter of the pipe to be used, by referring to the table below:

Size	PN10	PN16
16	–	13.4
20	–	16.6
25	–	21.0
32	–	26.9
40	–	33.7
50	–	42.2
63	–	53.0
75	–	63.4
90	–	76.1
110	–	93.0
160	143.9	–

2. Mark this diameter on Scale A.
3. Mark the required flow rate in litres per second on Scale B.
4. Draw a straight line connecting the points on Scales A and B and extend this to Scales C and D.
5. The velocity of the flow in metres per second is determined from the intersection with Scale C.
6. The frictional head loss in metres per 100 metres of pipe, can be read off Scale D.

Flow nomogram

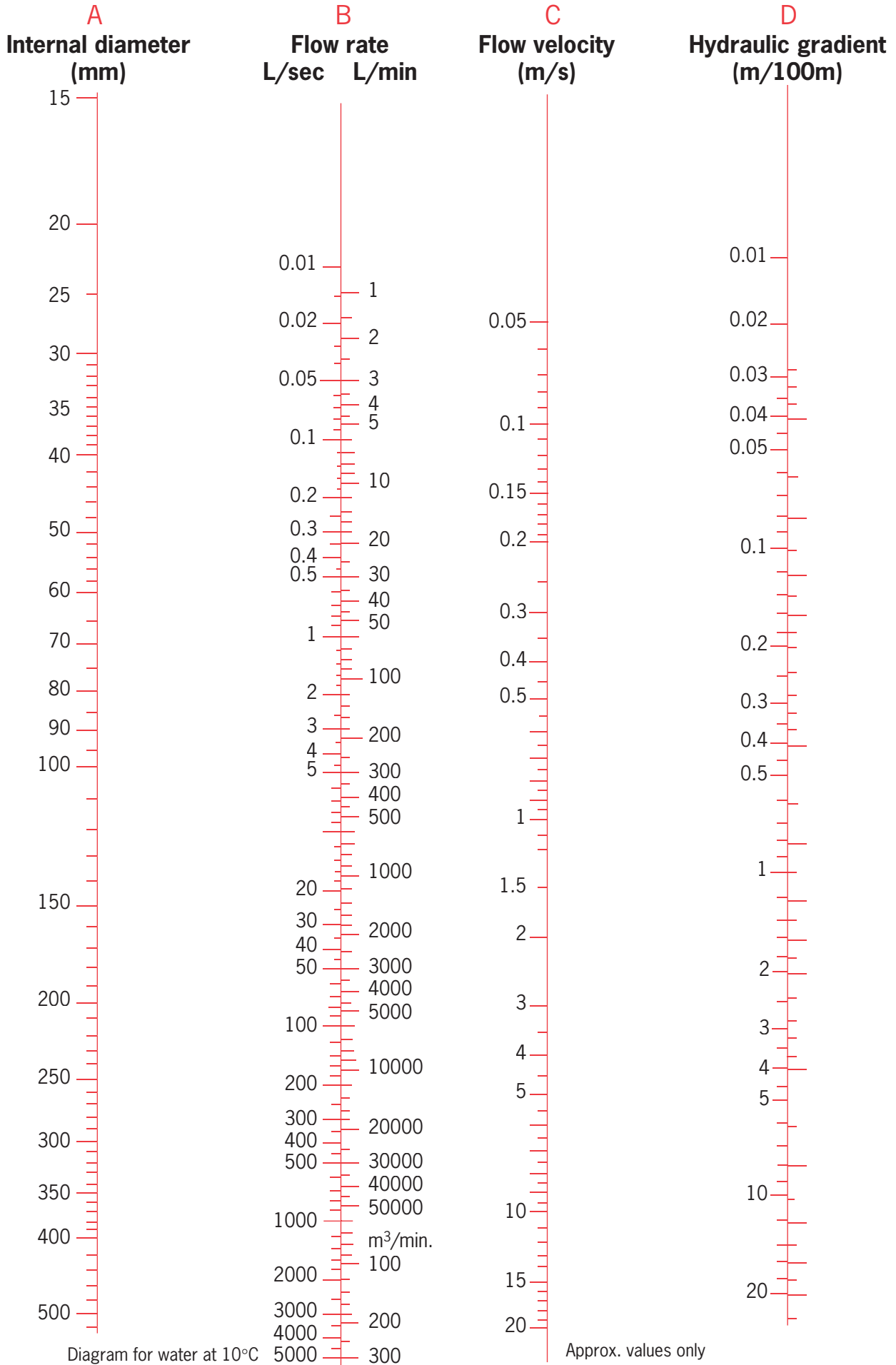

Approx. values only

Fittings

The calculation of pressure drop in fittings is more complex but calculations can be made for equivalent lengths of straight pipe using the Formula $E = F \times D$ where:

- E = the equivalent pipe length (metres)
- F = the fittings constant (see table below)
- D = the fitting internal diameter in mm.

To calculate the total pressure drop in the system, the equivalent straight pipe lengths for fittings is then added to the total straight pipe length to obtain the total drop.

Fittings Constant

Fitting

90° Elbow	0.030
45° Elbow	0.014
90° Tee – straight through	0.012
90° Tee – side branch	0.060
90° Long Radius Bends (4D)	0.008
90° Bend	0.012
45° Bend	0.009
Reducing Bush (per size reduction)	0.150
Butterfly Valves	0.128
VK Double Union Ball Valves	0.002
Diaphragm Valves	0.233
Check Valves	0.049

These values are included as a guide to facilitate calculation of overall system performance and should not be used in isolation.

Design of Supports

Supports/Brackets

The hanger type of support does not normally provide lateral restraint to the pipe and can encourage snaking. If hanger rods are used they should be made as rigid as possible and must allow free axial pipe movement.

All steel brackets in contact with the plastic system should be free of sharp edges to avoid damage to the pipe.

Support Centres

The recommended distance between supports for pipes with water is given in the table below. Where the contents have a specific gravity greater than 1 the distance must be decreased by dividing the recommended centre distance by the specific gravity.

PN16 Pipe									
Support Centres (m)									
	20°C	30°C	40°C	50°C	60°C	70°C	80°C	90°C	95°C
16	0.75	0.70	0.70	0.65	0.60	Continuous Support		Continuous Support	Continuous Support
20	0.80	0.75	0.75	0.70	0.65	0.50	0.50	Support	Support
25	0.85	0.80	0.80	0.75	0.70	0.60	0.55		
32	0.95	0.90	0.90	0.85	0.80	0.70	0.65		
40	1.05	1.00	1.00	0.95	0.90	0.80	0.75	0.50	
50	1.20	1.05	1.10	1.05	1.00	0.90	0.85	0.60	
63	1.35	1.30	1.25	1.20	1.15	1.10	1.05	0.80	
75	1.45	1.40	1.35	1.30	1.25	1.15	1.10	0.85	
90	1.60	1.55	1.50	1.40	1.35	1.20	1.15	0.90	
110	1.80	1.75	1.70	1.60	1.55	1.35	1.30	1.05	
160	2.00	1.90	1.85	1.80	1.75	1.60	1.40	1.10	

Clips

Any pipe clips used in conjunction with Durapipe Corzan must allow free axial pipe movement and afford lateral restraint. Durapipe Cobra pipe clips meet these requirements. A suitable alternative would be fabricated mild steel saddle clips, designed with a clearance between pipe and clip.



Support of heavy equipment

Large valves, filters and other heavy equipment should always be independently supported to prevent undue loading onto the Durapipe Corzan system. Durapipe valve support plates can be used in place of backing rings to satisfy this requirement.

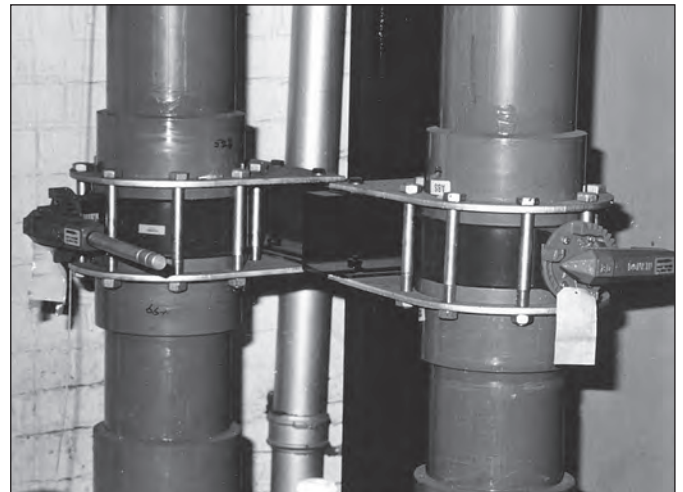

Pipe routing

Systems installed above ground should be designed such that there are sufficient changes in direction to accommodate expansion or contraction. The support method described earlier will ensure that the pipework can move axially, without snaking.

Utilize all available pipe flexibility. Do not place clips too close to changes in direction.

xPipe anchors

On complex systems, possibly involving several parallel pipe runs, the direction of movement can be controlled by use of anchor points at strategic positions, e.g. two pipe clips at either side of a fitting, or vice versa.

Construction of Typical Anchor Points

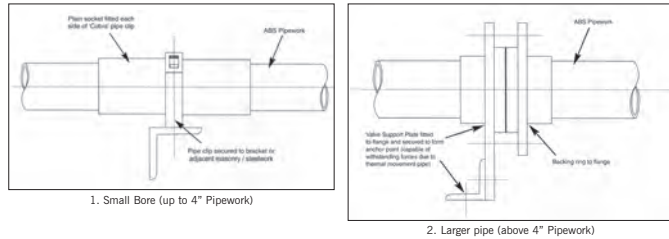

Do not use tight fitting clips. These can damage the pipework. The high coefficient of thermal expansion of plastic compared to metals as shown in the following chart, may result in considerable expansion and contraction of the pipe runs with changes in temperature.

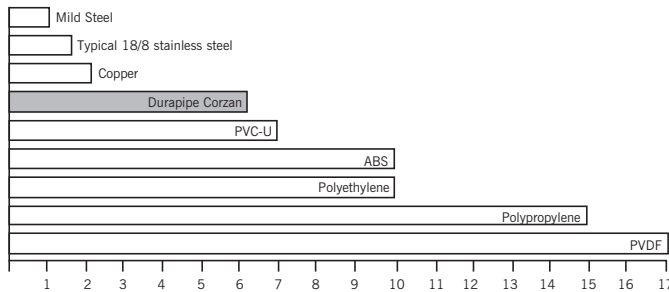

The thermal coefficient of linear expansion for Durapipe Corzan is $6.1 \times 10^{-5}/^{\circ}\text{C}$

A useful rule of thumb is that Durapipe Corzan pipes will expand (or contract) by 0.6mm/metre/10°C change in pipe mid wall temperature. The principle is to control expansion by constraining the pipe by lateral restraint. At the same time supports and clips must allow free axial movement.

Calculating expansion/contraction

The expansion and contraction of plastic pipe is a function of the change in average temperature of the pipe wall. This temperature depends on internal and external environmental temperatures and whether the environments are gaseous (air) or liquid. The most common case is a pipe conveying liquid surrounded by air.

Calculation

The following simple equations may be used for calculation of expansion or contraction under these conditions:

Symbols

- ΔT_L = Maximum temperature change in pipe contents
- ΔT_A = Maximum temperature change of external air
- ΔT = Change in average temperature of pipe mid-wall
- ΔL = Change in length of pipework section under consideration
- α = Coefficient of linear expansion of pipe material
- L = Original length of pipe
- α For Durapipe Corzan = $6.1 \times 10^{-5}/^{\circ}\text{C}$

To calculate pipe wall temperature change, use the equation $\Delta T = 0.65 \Delta T_L + 0.10 \Delta T_A$

Using value of ΔT thus calculated, calculate expansion $\Delta L = \Delta T \times L \times \alpha$

Example:

Determine the free leg length required to accommodate a change in length of 33 metres of 90mm diameter pipework caused by an increase in contents temperature from 20°C to 40°C, with the external air temperature also increasing from 5°C to 25°C.

- To calculate pipe mid wall temperature change (ΔT) apply the equation:

$$\Delta T = 0.65 \Delta T_L + 0.10 \Delta T_A$$
 therefore

$$\Delta T = 0.65 (40-20) + 0.10 (25-5)$$
 i.e.

$$\Delta T = 0.65 \times 20 + 0.10 \times 20 = 15^{\circ}\text{C}$$

Note: The common error when calculating ΔT is to use extremes of temperature, in this case 5°C for air and 40°C for contents. 35°C would then be used for ΔT in the next calculation instead of the correct 15°C which would give more than double the true value.

- To calculate expansion (ΔL)

$$\Delta L = \Delta T \times L \times \alpha$$
 therefore

$$\Delta L = 15 \times 33 \times 6.1 \times 10^{-5}/^{\circ}\text{C} = 0.0302\text{m} = 30.2\text{mm}$$

- To calculate free leg length

Using the value of $\frac{\Delta L}{2}$ draw a horizontal line on the graph from the vertical scale to meet the 3in or 90mm pipe gradient line. Drop a perpendicular from the intersection point to the horizontal scale. The figure obtained is the free leg length of loop required, which in this case is 1.03m.

Flexibility

The length of unrestrained pipe (free leg strength) required to accommodate expansion and contraction can be calculated from the graph below.

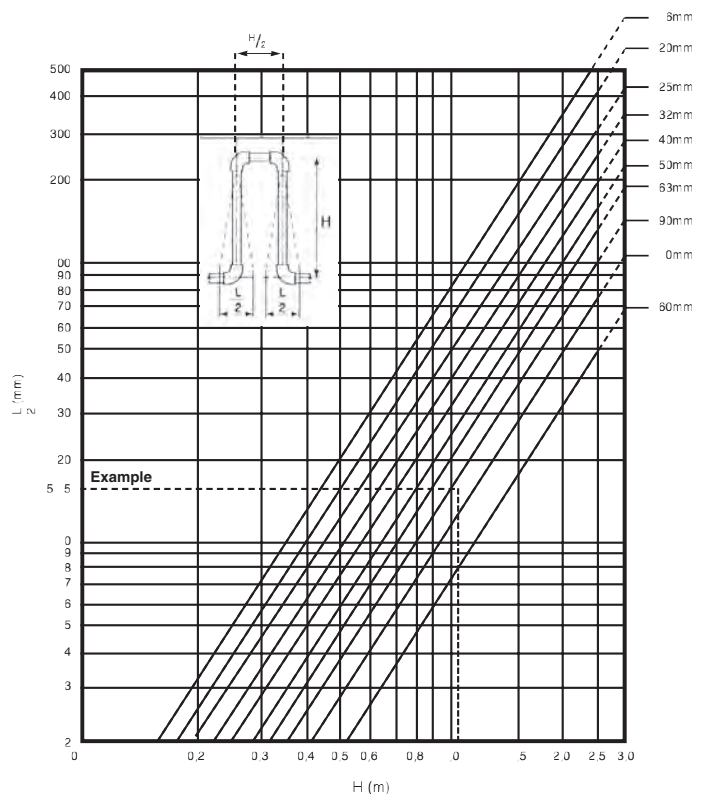

Expansion loops

A simple means of introducing flexibility is to incorporate expansion loops as shown below.



Rubber Bellows

Where space constraints prevent the flexibility of the pipework being utilized then flanged rubber bellows may be used. These must be of a design sufficiently pliable to flex without damage to the plastic pipe. The bellows manufacturer's instructions should be followed.

Thermal Insulation and Trace Heating

Whilst Durapipe Corzan piping systems have low thermal conductivity, situations may arise when trace heating and/or thermal insulations will be required.

Fibre 'wool' types of insulation such as 'Rockwool' are suitable for use with Durapipe Corzan but some materials used in the manufacture of certain types of trace heating tapes, thermal insulation and their adhesives, can have a detrimental effect on certain thermoplastics. Therefore, it is essential that material compatibility is checked with Durapipe UK before use.

Approval of any product is conditional on it being used strictly in accordance with the manufacturer's instructions for applications in conjunction with thermoplastic materials.

Buried pipes

Recommendations covering essential requirements for installations below ground may be summarised as follows:

In general, trenches should not be less than a metre deep. Trenches should be straight sided, approximately 300mm wider than the pipe diameter to allow proper consolidation of packing materials.

Trench bottoms should be as level as is practical.

Large pieces of rock, debris and sharp objects should be removed

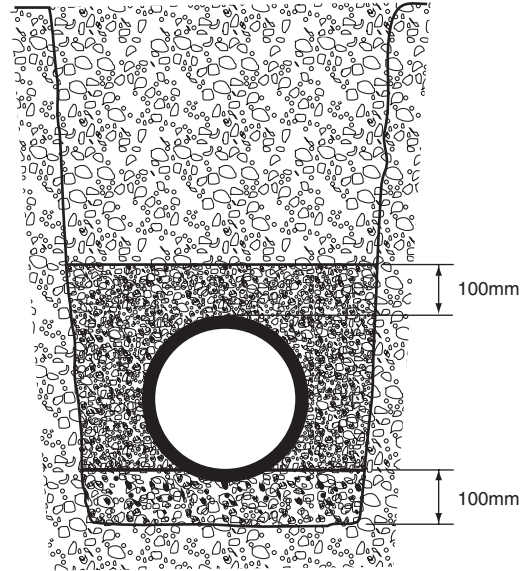

Alternatively gravel can be laid approximately 100mm deep on the floor of the trench. (Sand may be used but subterranean water is liable to wash sand away and leave the pipe unsupported.)

If pipes are jointed above ground, they should remain undisturbed for 2 hours before being lowered into the trench.

After laying, pipes should be covered with gravel or similar material to a depth of 100mm above the crown of the pipe. The gravel should be extended sideways to both trench walls and compacted. This should be done prior to testing, with joints left exposed.

Care should be taken to ensure that sharp objects, stones, etc, are prevented from falling into the trench before covering the pipe.

After pressure testing, joints should be covered with gravel or similar material, and back filling completed.

A section of pipe installed below ground to the above recommendations is shown in the illustration.

Jointing Procedure

Solvent cement welding

Joints can be made more quickly and more cheaply than by almost any other method. Durapipe Corzan solvent cement is specially formulated to withstand the same working conditions as the rest of the system.

The cements operate by chemically softening the outside of the pipe and the inside of the fittings and therefore the efficiency is greatly reduced if these surfaces are not absolutely clean and properly prepared.

The jointing process is simple and quick. The effectiveness of any joint depends upon thorough and correct execution of the following procedure.

Procedure

1. Cut the pipe clean and square. Durapipe Corzan pipe can be cut with either a saw, or circular bladed plastic pipe cutters.



2. Remove internal and external burrs and clean out swarf. File a lead chamfer, of 15°– 30° of approx 3mm. This prevents the solvent layer being sheared from the surface of the fitting when pushing the pipe fully home.

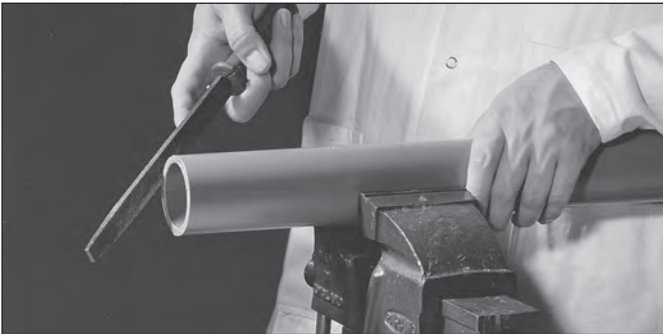

3. Next mark the pipe a known distance from the end and clear of the area to be abraded.

This should be used to check the pipe penetration into the socket after completion.



4. Abrade the end of the pipe over a length equal to the depth of the fitting socket, using clean, coarse emery cloth.

Durapipe pipes and matched fittings are designed for an interference fit. No attempt should be made to produce a clearance between pipes and fittings by excessive abrading.

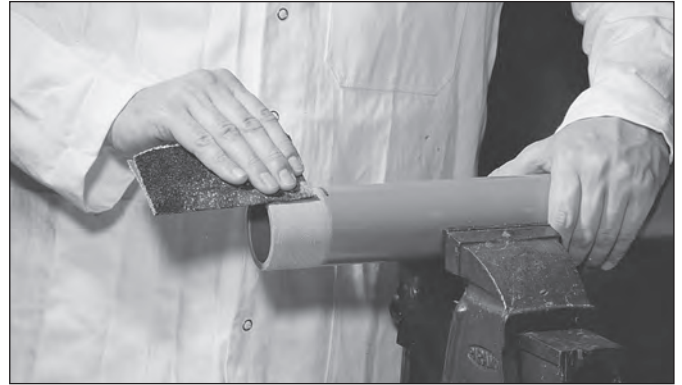

5. Abrade the socket of the fitting.



6. Clean thoroughly the abraded surfaces of pipe and fittings using lint free cloth, moistened with Durapipe ECO Cleaner.

7. Select Durapipe Corzan Solvent Cement and read the label on the tin (see note 1 overleaf).

8. Using a clean brush, approximately half as wide as the pipe diameter (see note 2), apply the cement to pipe and fitting using longitudinal strokes. The abraded areas should be completely covered with cement. Ensure that the cement is still liquid (to allow surfaces to slide) when pipe and fitting are assembled. It is important to apply cement quickly, to enable assembly without excessive force being required. (See Note 3).



9. Immediately after application of cement, push pipe fully home into the fitting. Do not twist but continue to exert the pressure necessary to hold the pipe into the fitting for times varying from 10 seconds on size 16mm to 45 seconds on size 160mm. The slight taper of Durapipe fittings may otherwise induce the pipe to slide out of the socket with consequent loss of joint shear strength.

Application of the correct amount of cement will result in a neat bead of cement at the edge of the fitting and at the edge of the pipe. Excessive deposits inside the fittings must be avoided. These can weaken the wall, particularly on small sizes.

10. Wipe off excess cement on the outside of the joint.



11. Replace lids on tins.
 12. Clean brush in ECO cleaner.

Note

1. The integrity of a Durapipe Corzan System may be affected if the appropriate Durapipe Cement is not used. Durapipe UK disclaims responsibility for any Durapipe Corzan System constructed with any other cements or not fabricated in accordance with the instructions contained herein.
2. On size 160mm use 3in wide brushes and 1 litre tins of cement.
3. To achieve the correct speed of application on size 160mm, cement should be applied simultaneously to pipe and fitting (two people required).

An indication of the number of joints likely to be made per litre of Durapipe solvent cement is:

Nominal Size mm	Joints per Litre PVC-C
16-32	300
40-63	120
75-90	50
110-160	15

The drying time for joints will vary with fit, amount of solvent cement applied, ambient temperature and working pressure.

It is recommended that wherever possible, joints are left to cure for 24 hours before pressure testing. However, it is recognised that there will be times when joints will need to be put into service within a few hours of being made.

A rough but safe working guide, where contents temperature will not exceed 20°C, is 1 hour per 1 bar pressure for systems up to and including 110mm diameter. For 160mm increase this time to 1½ hours per 1 bar pressure. In any event joints should be allowed to cure for a minimum of 4 hours.

Precautions

Always use clean brushes.
 Always use clean lint-free cloth or paper towels.
 Always use Durapipe Corzan solvent cement.
 Always replace lids on tins when not in use.
 Never dilute Durapipe Corzan solvent cement with ECO cleaner.
 Use a shelter to keep jointing surfaces dry in wet weather.
 Solvent cement and cleaners are hazardous, flammable materials. Please refer to the Safety Data Sheet supplied with Durapipe Corzan Solvent Cement and ECO Cleaner, for details on suitable safety requirements.
 Do not joint near naked flames, and avoid smoking in the working area – Durapipe Corzan solvent cement is highly flammable.
 Do not use cements or cleaners in confined spaces. Concentrated vapours may cause dizziness.
 Durapipe UK do not recommend solvent cement jointing of dissimilar materials e.g. Durapipe Corzan to ABS, or Durapipe Corzan to PVC-U. However, the practice may have limited success as a temporary repair, providing that both materials are suitable for the application in question. In such cases, Durapipe Corzan solvent cement must be used and the jointing procedure must be in strict accordance with the details given in this brochure.

Threaded Systems

Durapipe Corzan is produced as metric pipe only and the outside diameter is not compatible with BSP Thread requirements.
 Durapipe UK manufactures threaded adaptor fittings for use where threaded connections are required in Durapipe Corzan systems.
 Assembly should be carried out by hand with final tightening by a strap wrench, if necessary.
 Extra care must be taken not to over tighten or damage the thread. Pipe wrenches must **never** be used.
 PTFE tape should be wound on to male threads prior to jointing to ensure a satisfactory seal.

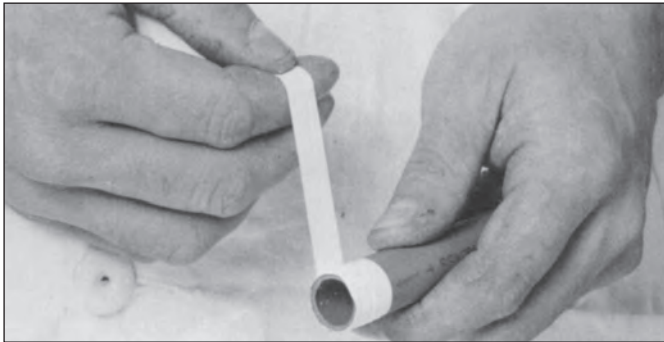

Warning

Anaerobic adhesive thread sealants e.g. Loctite 542, 572 can chemically attack PVC-C and must not be used. We recommend the use of PTFE tape as shown.

Reducing Bushes

Reducing bushes offer a neat and simple method of reducing socket size in the minimum of space.
 Care must be taken to prepare properly all jointing surfaces as recommended earlier, with the end of the bush being chamfered (unless a moulded chamfer is included).

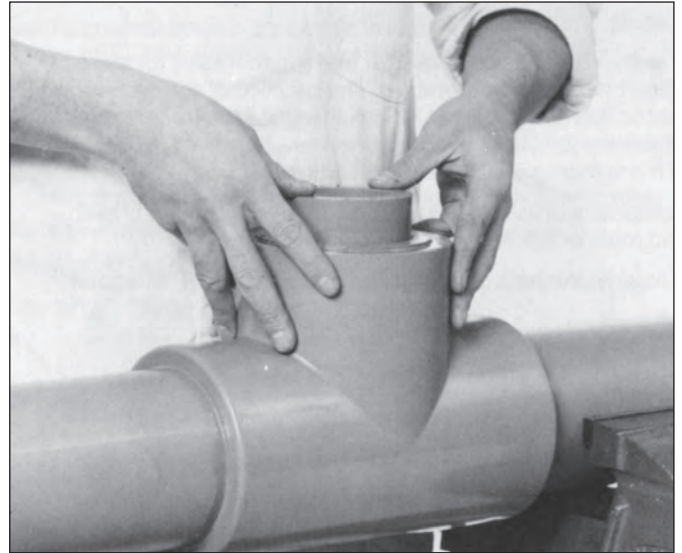

Connections – Plastics to metal

There are several recommended methods of connecting metal and plastic systems.

- Composite unions;
- Flanges;
- Male threaded fittings;
- Female threaded fittings

Plastics expand or contract far more than metals for any given change in temperature. The practice of connecting plastic threaded fittings to metal threads is not recommended where the joint is likely to experience a temperature change of more than $\pm 5^{\circ}\text{C}$, otherwise leaks may occur.

In such situations the PVC-C/brass composite unions must be used.

Connections for instrumentation

Instrumentation connections can be made by drilling through pipe and socket where the material is at its thickest and tapping the hole to receive a threaded fitting, as shown below:

Pipe size	Size of connection
16mm-63mm	Use tees, reducing bushes and threaded fittings.
75mm-110mm	Max. tapping $\frac{1}{2}$ BSP.
125mm-140mm	Max. tapping $\frac{3}{4}$ BSP.
160mm	Max. tapping 1 BSP.

Such connections, if correctly drilled and tapped with a full thread form, will be limited to a PN10 rating.

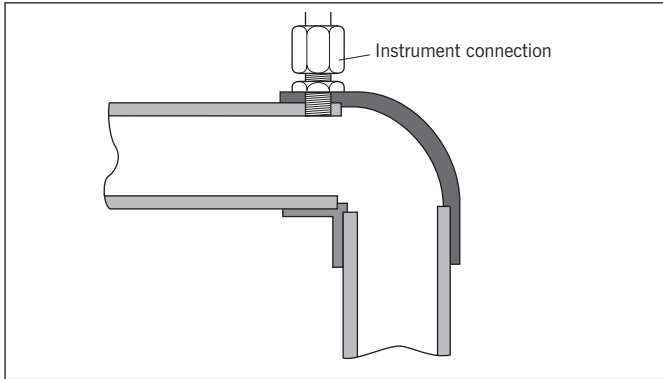

Flanged joints

Stub flanges are available from 20mm to 160mm.

The correct galvanised mild steel backing ring and rubber gasket must be used with both types.

Flange bolting procedure

The following procedure is recommended for installing Durapipe Corzan flanges:

1. Inspect flange faces and ensure that they are clean and undamaged.
2. Check the correct backing ring and rubber gaskets have been supplied. Durapipe UK supplies a matched system of flanges and backing rings – do not interchange Metric and Imperial components.
3. Loosely assemble flanges. Ensure that flanges and bolt holes align and that the flange faces are parallel. Ensure that the gasket is correctly positioned between the flanges.
4. Ensure that the appropriate sized washer are placed under both bolt heads and nuts.
5. Tighten the nuts and bolts in a diagonally opposite sequence (see below) to ensure even loading around the flange to avoid distortion. It is recommended that the nuts and bolts be tightened as uniformly as possible progressively from a finger tight start.
6. Repeat as necessary until recommended torque value at all bolts is achieved.

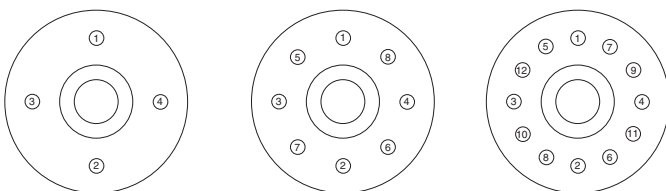

Recommended Torque Values (Nm)

Size	Torque
16	15
20	15
25	15
32	15
40	20
50	30
63	35
75	40
90	40
110	40
125	50
140	50
160	60

Threaded adaptors

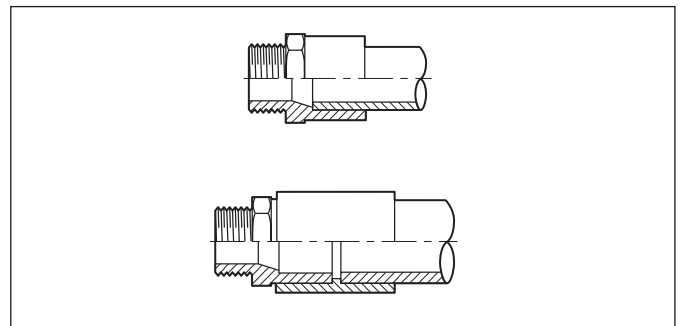

Male threaded adaptors incorporate two controlled diameters on the plain end and can be used as shown.

Reducing bushes

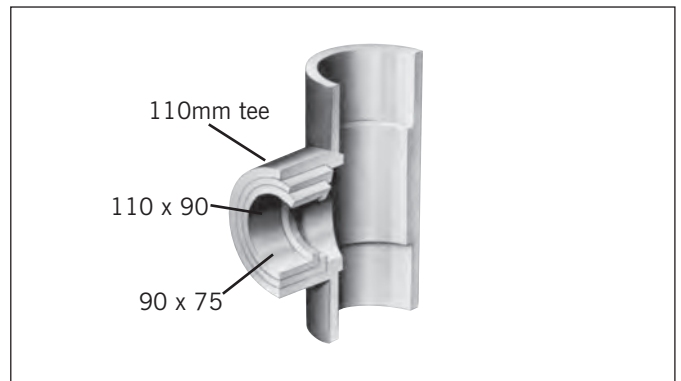

Durapipe UK reserves the right to alter specifications without prior notice.

The specifications and other particulars contained herein must be read in conjunction with any code of practice affecting a particular industry. The code of practice should always be followed if there is any conflict with particulars herein.

General Information

Handling and storage

The high impact strength of Durapipe Corzan systems provides some protection against damage but care should be taken at all stages of handling, transportation and storage.

Pipe must be transported by a suitable vehicle and properly loaded and unloaded, e.g., wherever possible moved by hand or mechanical lifting equipment. It must not be dragged across the ground.

The storage should be flat, level and free from sharp stones.

Pipes should not be stacked to heights exceeding the following as this can lead to pipe distortion:

Pipe size	Max. Stacking height
Up to 90mm/3in	20 x pipe size
125-200mm/4in-6in	12 x pipe size
225mm/8in	7 x pipe size

Smaller pipes may be nested inside larger pipes. Side bracing should be provided to prevent stack collapse.

Similar precautions should be taken with fittings and these should be kept in protective wrappings until required for use.

Weathering

Prolonged storage (greater than 1 month) or storage in areas where high temperature is anticipated, the stack height should never exceed 4 layers or 1 metre maximum height. Such stacks should be protected from the effects of weathering (particularly ultra violet exposure which can cause some deterioration in Durapipe Corzan) by placing an opaque covering over them. If fixed to the side bracing the sheets will provide protected and shaded conditions and allow a free passage of air around the pipes.

Where the pipes are to be installed in locations likely to be permanently exposed to prolonged periods of strong sunlight, such as in tropical countries, the life can be extended by painting the pipe with household gloss of emulsion. Cellulose based paints should only be used with extreme care and close attention paid to the manufacturers instructions.

Pipe contents identification

Do not put self-adhesive labels directly onto pipe surfaces as this can cause stress cracking. It is recommended that some sort of barrier such as aluminium foil, is placed between the pipe and identification label.

Testing

It is suggested that the following test procedure be followed, after joints have been allowed to dry for the appropriate minimum time (at least 24 hours):

The system should be divided conveniently into test sections.

Fill the section with cold water making sure that no air pockets remain. Do not pressurise at this stage, but leave for at least 1 hour to allow equilibrium temperature to be reached.

Check the system for leaks. If no leaks are apparent check for and remove any remaining air. Increase pressure up to 50lbf/in² or 3 bar. *Do not pressurise further at this stage.

Leave the section pressurised for 10 minutes. If the pressure decays, inspect for leaks and rectify as necessary.

If the pressure remains constant, slowly increase the hydrostatic pressure to 1½ times the nominal operating pressure. (Test pressure)

Leave the section pressurised for a period not exceeding 1 hour. During this time the pressure should not change.

Caution

Personnel must stand well clear when pressure testing systems.

Similarly, under no circumstances should pressure tests be carried out using pressurised gases. Such a test could be extremely dangerous and does not serve any useful purpose.

Note: If extended times are required to achieve hydrostatic pressure, either leakage has occurred or air remains in the line. Inspect for leakage and if none is apparent, reduce the pressure and check for trapped air which must be removed before further pressurisation is commenced.

If a leakage source is difficult to establish it is acceptable to pressure the line using air or nitrogen to a maximum pressure of 25lbf/in² or 1½ bars. Test joints etc. with a soap solution.

Health and Safety at Work Act and COSHH Regulations

Attention is drawn to the requirements in the U.K. of this Act and to the 1988 Control of Substances Hazardous to Health (COSHH) Regulations. Advice on care to be taken in handling and storage of Durapipe UK products is available from Durapipe Technical Support Department. Durapipe UK cannot accept responsibility for accidents arising from the misuse of its products because of bad installation or incorrect application.

Dimension specifications and general notes

Dimensions and standards

Dimensions are in accordance with the following standards:

Durapipe Corzan	pipe, outside diameter	DIN8079
	pipe quality and test methods	DIN8080
	fittings socket dimensions	DIN8063

Socket dimensions are as follows:

Da	DN	A
16	10	14
20	15	16
25	20	18.5
32	25	22
40	32	26
50	40	31
63	50	37.5
75	65	43.5
90	80	51
110	100	61
125	110	68.5
140	125	76
160	150	86

Da	Pipe outside diameter
DN	Nominal bore
A	Minimum socket depth

The sockets of the fittings are slightly tapered with the diameter decreasing from the mouth to the root. The maximum included angle of the taper is 0° 30'.

Durapipe UK threaded fittings conform to the nominal requirements of BS21/DIN 2999/ISO7.

Maximum Continuous Pressure Rating

Pipes, fittings and valves are designed to operate continuously for 50 years at their maximum rated pressure at 20°C plus retain a safety factor of ≥ 2 as follows except where otherwise stated.

Durapipe Corzan Pipe	PN16 – 16mm to 110mm
	PN10 – 160mm
Fittings	PN16 – 16mm to 160mm

Threaded fittings are designed for use up to 16 bar at 20°C.

Valves:- The pressure ratings are shown individually.

Marking

Pipes and fittings are marked with the following information:

- Name or trade mark
- Material
- Pressure rating
- Size
- Relevant standard numbers are included where applicable with the certifying symbol.

Valves

A comprehensive range of Durapipe UK valves to match the Durapipe Corzan range is available including:

VK Ball Valves – with unique external micro adjustment

VM Diaphragm Valves

SR Single Union Ball Check Valves

FK Butterfly Valves

For further information on the various valves available please refer to Catalogue No. D0894.

Ordering by code

Durapipe UK code numbers should be used when ordering product. The eight digit code is structured as follows:

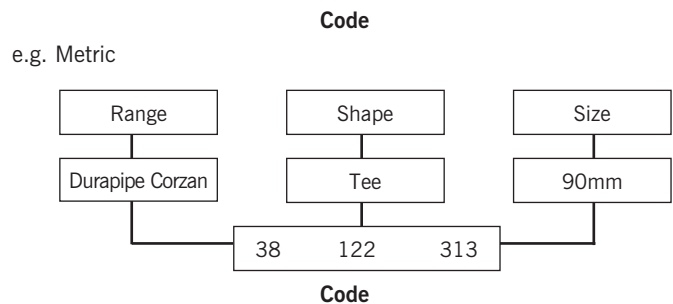

Metric/Inch pipe dimensional comparison tables

The change to the use of the metric system of units and the adoption of metric standards, has been a slow and often confusing process. Although scientific and educational establishments have adopted metrication in full, many areas of industry and commerce have not. The pipework industry is no exception, with pipe still being produced in both inch and metric (millimetre) sizes.

Compromises such as designating inch pipe in millimetres (usually referred to as a soft metric conversion) only serves to confuse the situation further and should be avoided. **Durapipe UK produces thermoplastic systems in both inch and metric sizes.** Tabulated below is a comparison of PVC-U inch sized pipe conforming dimensionally to the sizes listed in BS3505 and Durapipe Corzan metric sized pipe.

The systems are designated differently, the inch system relates to nominal bore; the metric system relates to the outside diameter. Both systems are produced with the outside diameter as the controlled dimension. This enables the same fitting of any particular size to be used in conjunction with all classes of pipe.

Threaded systems

Durapipe Corzan pipe is not produced with an outside diameter compatible to BSP Thread requirements. Durapipe UK manufactures threaded adaptor fittings for use where threaded connections are required in the metric system.

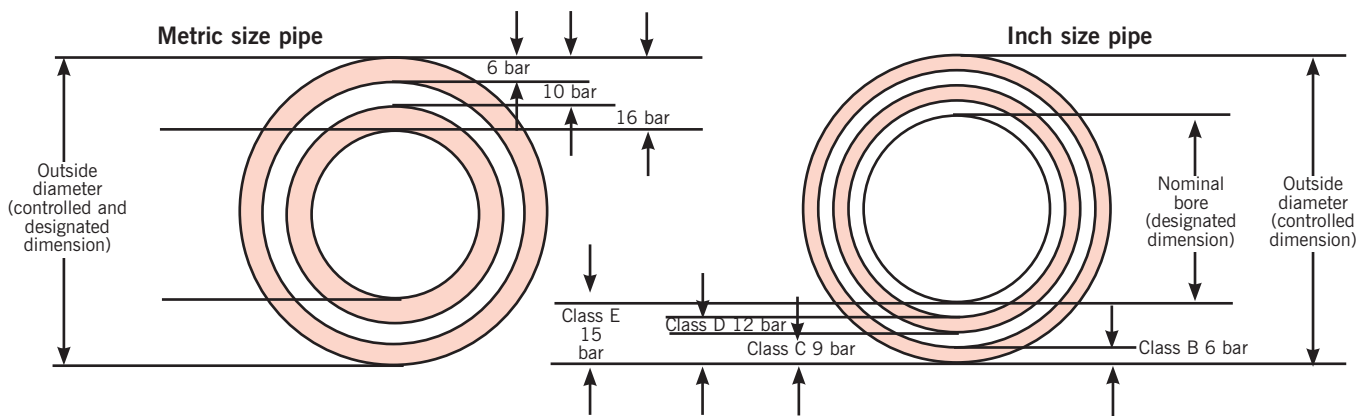

Durapipe Corzan Metric System		Durapipe PVC-U Inch System (BS3505)		
Designated size (outside diameter) (mm)	Bore diameter PN16 PVC-C (mm)	Designated size (nominal bore) (in)	Bore diameter Class E PVC-U (mm)	Outside diameter (mm)
20	17	1/2	18	21.4
25	21	3/4	22	26.7
32	27	1	29	33.6
40	34	1 1/4	36	42.2
50	42	1 1/2	41	48.3
63	53	2	52	60.3
75	64			
90	77	3	77	88.9
110	94	4	100	114.3
160*	145	6	145	168.3

*160mm PN10 rated.

Index to Durapipe Corzan fittings

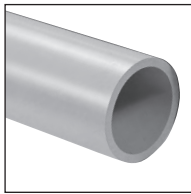

Pipes (plain)
page 20

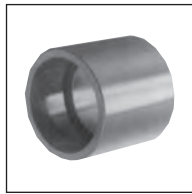

Sockets (plain)
page 20

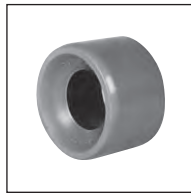

Reducing bushes
(plain)
page 20



Elbows 45° (plain)
page 21

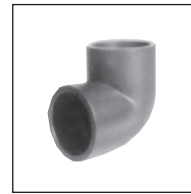

Elbows 90° (plain)
page 21



Tees (plain)
page 21



Tees (reducing)
page 21



Composite unions
female brass
page 22



Composite unions brass
page 22



Caps (plain)
page 22



Tees threaded/branch
page 22



Socket unions (plain)
page 23



Adaptor nipples
page 23



Elbows 90° (plain/
threaded)
page 23



Adaptor sockets
page 23



Socket unions (plain/
threaded)
page 24



Adaptor socket unions
(inch/mm plain)
page 24

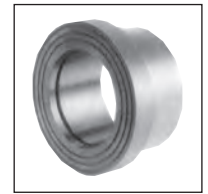

Flanges stub serrated
page 24

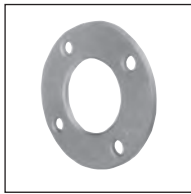

Backing rings
page 25



Valve support plates
page 25

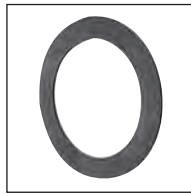

Gaskets flat
page 26

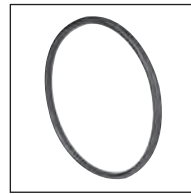

'O'-rings
page 26



Cobra clips
page 26



Solvent cement
and cleaner
page 26



VK double union ball
valves (manual)
page 28



Pressure relief valves
page 29



Diaphragm valves
(manual)
page 28



Diaphragm valves
(pneumatic)
page 28



Butterfly valves
(manual)
page 29



Ball check valves
page 28

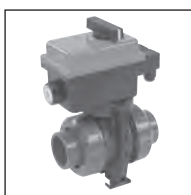

Actuated valves
(electric and pneumatic)
page 29

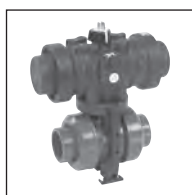

Actuated valves
(electric and pneumatic)
page 29

Pipe Durapipe Corzan plain

PN16

Size d1	t	SL	kg/m	Code
16	1.2	5	0.11	38 560 305
20	1.5	5	0.17	38 560 306
25	1.9	5	0.26	38 560 307
32	2.4	5	0.42	38 560 308
40	3.0	5	0.63	38 560 309
50	3.7	5	0.97	38 560 310
63	4.7	5	1.53	38 560 311
75	5.6	5	2.20	38 560 312
90	6.7	5	2.88	38 560 313
110	8.2	5	4.31	38 560 314
*160	7.7	5	6.06	38 555 317

*PN10

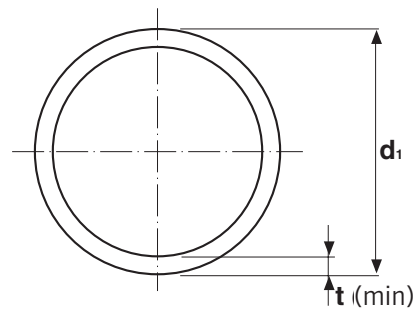

Sockets plain

Size	A	B	Z1	gms	Code
16	22	31	3	9	38 100 305
20	27	35	3	11	38 100 306
25	33	41	3	21	38 100 307
32	41	47	3	31	38 100 308
40	50	55	3	58	38 100 309
50	61	65	3	90	38 100 310
63	75	79	3	160	38 100 311
75	89	91	3	260	38 100 312
90	108	107	5	465	38 100 313
110	130	131	9	750	38 100 314
160	186	181	9	1820	38 100 317

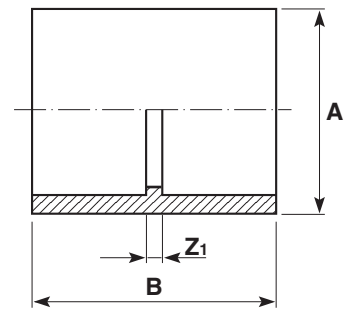

Reducing bush plain

Size	B	Z1	gms	Code
20 x 16	16	2	3	38 109 412
25 x 20	19	3	6	38 109 415
32 x 20	22	6	16	38 109 418
32 x 25	22	3	11	38 109 419
*40 x 20	26	10	27	38 109 421
*40 x 25	26	7	26	38 109 422
40 x 32	26	4	18	38 109 423
*50 x 32	31	9	39	38 109 426
50 x 40	31	5	35	38 109 427
*63 x 32	38	16	81	38 109 430
*63 x 40	38	11.5	84	38 109 431
63 x 50	38	7	70	38 109 432
*75 x 50	44	12	126	38 109 437
75 x 63	44	6	92	38 109 438
*90 x 50	51	20	213	38 109 442
*90 x 63	51	13	209	38 109 443
90 x 75	51	7	159	38 109 444
*110 x 63	61	23	365	38 109 449
*110 x 75	61	17	386	38 109 450
110 x 90	61	9	297	38 109 451
*160 x 110	86	25	1040	38 109 474

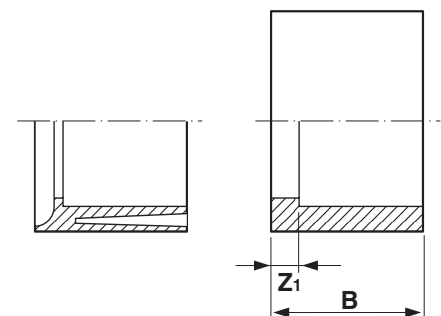

*Relief configuration (see drawing insert)

Elbow 45° plain

Size	A	C	Z ₁	gms	Code
20	28	21.5	5.5	20	38 119 306
25	34	25	6	32	38 119 307
32	42.5	29.5	7.5	58	38 119 308
40	52	36.5	10.5	101	38 119 309
50	64	42.5	11.5	175	38 119 310
63	80	52	14	305	38 119 311
75	90	61	17	344	38 119 312
90	107	72.5	21.5	587	38 119 313
110	130	87	26	1007	38 119 314
160	192	124	38	3255	38 119 317

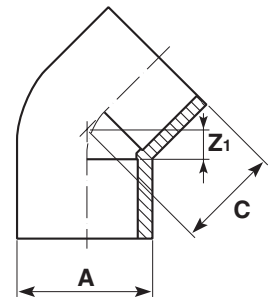

Elbow 90° plain

Size	A	C	Z ₁	gms	Code
16	22	23	9	12	38 115 305
20	27	27	11	20	38 115 306
25	33	34	15	34	38 115 307
32	41	39	17	56	38 115 308
40	50	48	22	95	38 115 309
50	61	58	27	155	38 115 310
63	76	72	34	283	38 115 311
75	91	84	40	490	38 115 312
90	107	99	48	745	38 115 313
110	130	121	60	1265	38 115 314
160	193	175	89	4500	38 115 317

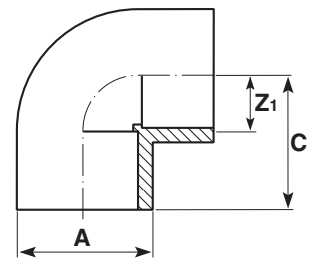

Tees 90° equal

Size	A	B	C	Z ₁	gms	Code
16	22	37	23	9	15	38 122 305
20	27	43	27	11	25	38 122 306
25	33	52	33	14	45	38 122 307
32	41	62	40	18	75	38 122 308
40	50	74	48	22	125	38 122 309
50	61	89	58	27	195	38 122 310
63	76	110	72	34	394	38 122 311
75	91	128.5	84.5	40.5	667	38 122 312
90	109	150.5	99.5	48.5	1075	38 122 313
110	133	183	122	61	1920	38 122 314
160	192	261	175	89	5730	38 122 317

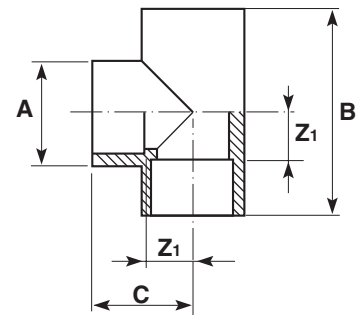

Tees 90° reducing

Size	A	B	C	D	Z ₁	Z ₂	gms	Code
25 x 20	33	52	30	28	14	14	41	38 124 415
32 x 20	41	61.5	33.5	28	17.5	17.5	66	38 124 418
32 x 25	41	61.5	36.5	34	17.5	17.5	72	38 124 419
40 x 20	50	74	38	29	22	22	111	38 124 421
40 x 25	50	74	41	34	22	22	111	38 124 422
50 x 25	61	89	46	35	27	27	176	38 124 425
50 x 32	61	89	49	42	27	27	182	38 124 426
63 x 25	76	109.5	52.5	36	33.5	33.5	320	38 124 429
63 x 32	76	109.5	55.5	43	33.5	33.5	325	38 124 430
75 x 25	91	128.5	55	33	40.5	39	470	38 124 434
90 x 25	109	150.5	62	33	48.5	46	773	38 124 439
110 x 25	133	183	72	33	61	56	1170	38 124 445

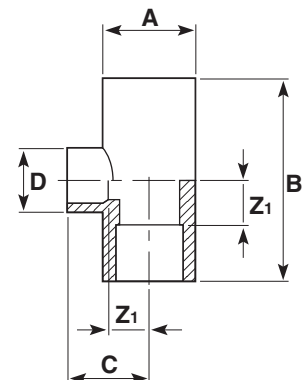

Composite unions plain/BSP threaded female brass

Size	A	B	Z ₁	gms	Code
16 x 3/8"	34	39	3	90	38 216 305
20 x 1/2"	40	46	3	145	38 216 306
25 x 3/4"	48	52	3	240	38 216 307
32 x 1"	55	57	3	275	38 216 308
40 x 1 1/4"	65	64	3	465	38 216 309
50 x 1 1/2"	79	70	3	515	38 216 310
63 x 2"	88	80	3	805	38 216 311

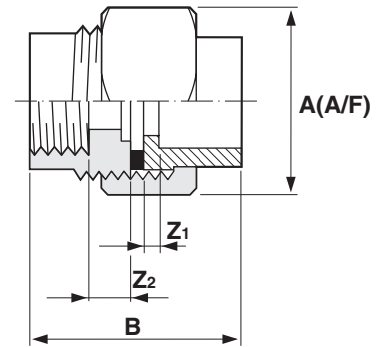

Composite unions plain/BSP threaded male brass

Size	A	B	Z ₁	gms	Code
16 x 3/8"	34	50	3	90	38 217 305
20 x 1/2"	40	59	3	145	38 217 306
25 x 3/4"	48	75	3	240	38 217 307
32 x 1"	55	81	3	275	38 217 308
40 x 1 1/4"	65	86	3	465	38 217 309
50 x 1 1/2"	79	99	3	515	38 217 310
63 x 2"	88	113	3	805	38 217 311

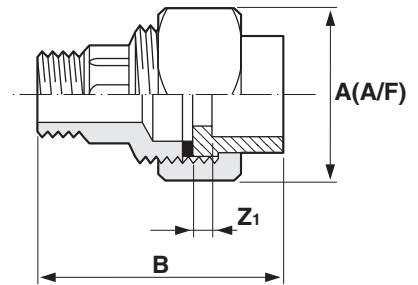

Tees 90° threaded branch with reinforcing ring

Size	A	B	C	D	Z ₁	Z ₂	gms	Code
16 x 3/8"	23.5	37	22.4	24.5	9	11	25	38 121 305
20 x 1/2"	28.5	44	28	29.5	12	13	40	38 121 306
25 x 3/4"	35	53	33.3	36	15	17	63	38 121 307
32 x 1"	43	62	40.1	44	18	21	118	38 121 308
40 x 1 1/4"	50	73.5	48.4	51	21.5	27	137	38 121 309
50 x 1 1/2"	61	89	58.4	62	27	37	231	38 121 310
63 x 2"	76	109.5	71.7	77	33.5	46	457	38 121 311

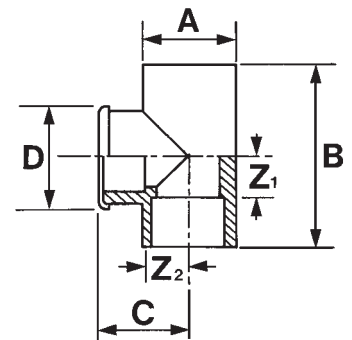

Caps plain

Size	A	B	gms	Code
20	28	23	9	38 140 306
25	34	27	16	38 140 307
32	41	31	25	38 140 308
40	51	36	42	38 140 309
50	62	43	64	38 140 310
63	77	51	115	38 140 311
75	91	59	205	38 140 312
90	110	69	260	38 140 313
110	132	83	555	38 140 314

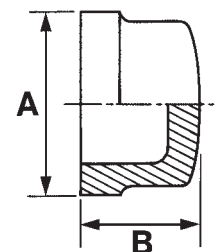

Socket union plain

Size	A	B	Z ₁	gms	Code
16	33	41	13	23	38 205 305
20	41	45	13	39	38 205 306
25	50	51	13	68	38 205 307
32	58	57	13	94	38 205 308
40	72	67	15	163	38 205 309
50	79	79	17	190	38 205 310
63	98	98	22	355	38 205 311

"O"-ring EPDM. For FPM "O"-ring order "204" type

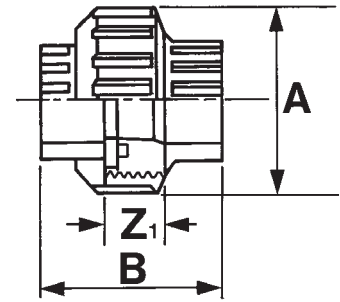

Adaptor Nipple plain female/threaded male

Size	A	B	Z ₁	gms	Code
16 x 20 3/8"	22	34	20	7	38 171 332
20 x 25 1/2"	28	41	25	13	38 171 334
25 x 32 3/4"	34	46	27	23	38 171 336
32 x 40 1"	42	52.5	30.5	38	38 171 338
40 x 50 1 1/4"	52	61	35	65	38 171 340
50 x 63 1 1/2"	65	66	35	113	38 171 342
63 x 75 2"	75	79	41	158	38 171 345

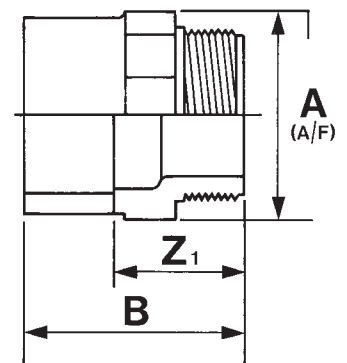

Elbow 90° plain/threaded with reinforcing ring

Size	A	B	C	D	Z ₁	Z ₂	gms	Code
16 x 3/8"	23.5	24	24.4	24.5	10	13	22	38 178 602
20 x 1/2"	28.5	28	28	29.5	12	13	33	38 178 306
25 x 3/4"	35	33	33.3	36	14	17	53	38 178 307
32 x 1"	43	40	39.6	44	18	20.5	94	38 178 308
40 x 1 1/4"	50	48	48.4	51	22	27	104	38 178 309
50 x 1 1/2"	61	58	58.4	62	27	37	203	38 178 310
63 x 2"	76	71	71.7	77	33	46	380	38 178 311

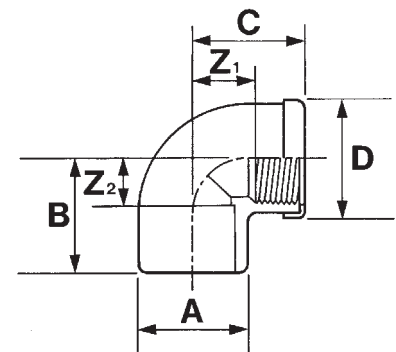

Adaptor Socket plain/threaded with reinforcing ring

Size	A	B	C	Z ₁	gms	Code
16 x 3/8"	23.5	31	11.4	5.6	15	38 103 602
20 x 1/2"	28.5	35	15	4	25	38 103 306
25 x 3/4"	35	40.3	16.3	5	38	38 103 307
32 x 1"	43	47.1	19.1	6	58	38 103 308
40 x 1 1/4"	50	52.4	21.4	5	66	38 103 309
50 x 1 1/2"	61	60.4	21.4	8	109	38 103 310
63 x 2"	76	71.2	25.7	7.5	196	38 103 311

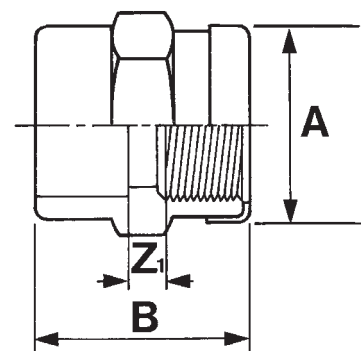

Socket Union plain/threaded

Size	A	B	C	Z ₁	gms	Code
16 x 3/8"	33	41	11.4	15.6	25	38 202 305
20 x 1/2"	41	45	15	14	40	38 202 306
25 x 3/4"	51	51	16.3	15.7	68	38 202 307
32 x 1"	58	56.7	19.1	15.9	93	38 202 308
40 x 1 1/4"	72	67	21.4	19.6	158	38 202 309
50 x 1 1/2"	79	72	21.4	19.6	193	38 202 310
63 x 2"	98	87.7	25.7	24	345	38 202 311

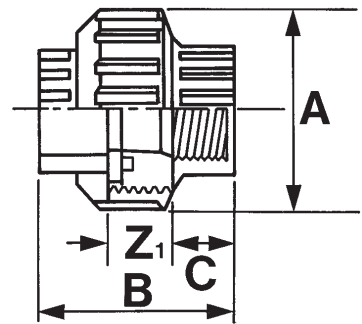

Adaptor Socket Union inch/metric plain

Size	A	B	Z ₁	gms	Code
16 x 3/8"	33	41	15.6	25	38 346 305
20 x 1/2"	41	45	14	40	38 346 306
25 x 3/4"	51	51	15.7	68	38 346 307
32 x 1"	58	57	15.9	93	38 346 308
40 x 1 1/4"	72	67	19.6	158	38 346 309
50 x 1 1/2"	79	72	19.6	193	38 346 310
63 x 2"	98	87.7	24	345	38 346 311

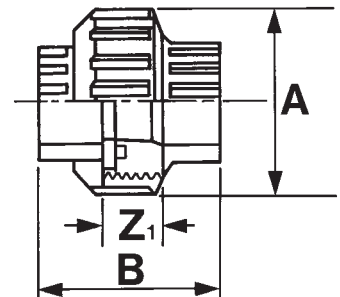

Flanges stub serrated

Size	A	B	D	Z ₁	gms	Code
20	34	19.5	7	3.5	11	38 135 306
25	41	22	7	3	17	38 135 307
32	50	25	7	3	27	38 135 308
40	61	29	8	3	43	38 135 309
50	73	34	8	3	66	38 135 310
63	90	41	9	3	116	38 135 311
75	103	47	10	3	175	38 135 312
90	125	56	10	5	305	38 135 313
110	150	65	12	4	490	38 135 314
160	212	90.5	16	4.5	1240	38 135 317

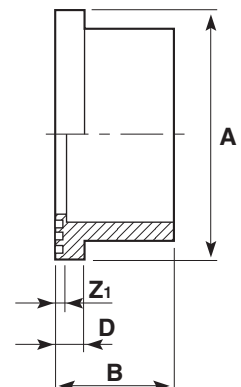

Backing rings galvanised mild steel

DIN 2501 16 bar/PN16

Size	A	B	K	L	No. Holes	gms	Code
16	90	7	61	14	4	240	13 421 305
20	96	6	65	14	4	300	13 421 306
25	106	7	75	14	4	320	13 421 307
32	116	7	85	14	4	350	13 421 308
40	142	7	100	18	4	420	13 421 309
50	152	7	110	18	4	710	13 421 310
63	165	8	125	18	4	1010	13 421 311
75	186	9	145	18	4	1280	13 421 312
90	201	9	160	18	8	1380	13 421 313
110	220	9	180	18	8	1430	13 421 314
125	253	8	210	18	8	1960	13 421 315
140	251	11	210	18	8	2060	13 421 316
160	286	11	240	22	8	2700	13 421 317
200	340	11	295	22	12	3830	13 420 318
225	340	11	295	22	12	3190	13 420 319
250	405	16	355	26	12	9450	13 420 320
315	460	20	410	26	12	8400	13 420 323

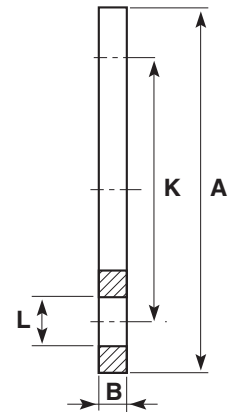

DIN 2501 10 bar/PN10

Size	A	B	K	L	No. Holes	gms	Code
200	340	11	295	22	8	3830	13 421 318
225	340	11	295	22	8	3190	13 421 319
250	396	16	350	22	8	9450	13 421 320
315	448	20	402	22	12	8400	13 421 323

ANSI CLASS 150

Size	A	B	K	L	No. Holes	gms	Code
20	90	8	61	16	4	300	13 448 306
25	100	8	70	16	4	380	13 448 307
32	110	9	79	16	4	480	13 448 308
40	118	8	90	16	4	530	13 448 309
50	129	8	99	16	4	590	13 448 310
63	154	10	121	19	4	1050	13 448 311
90	192	11	153	19	4	1470	13 448 313
110	230	11	190	19	8	2080	13 448 314

*The 200mm (NW175) stub flange supplied by Durapipe UK when used in conjunction with backing ring; code number 421 318 has a bolt circle diameter which matches 225mm (NW200) valves and fittings (295mm)

Valve support plates galvanised mild steel

DIN 2501 16 bar/PN16

Size	B	C	E	K	L	M	N	No. Holes	gms	Code
16	91	84	50	60	14	16	2	4	370	31 459 305
20	97	86	49	65	14	16	2	4	640	31 459 306
25	105	89	76	75	14	16	2	4	750	31 459 307
32	114	96	77	86	14	12	2	4	860	31 459 308
50	150	125	100	110	14	22	2	4	1480	31 459 309
63	160	134	100	125	14	24	2	4	2100	31 459 310
75	185	144	125	144	14	22	2	4	2500	31 459 311
90	203	150	127	160	14	23	2	8	2660	31 459 312
110	214	160	150	179	14	22	3	8	2960	31 459 314

N = No. of holes in base

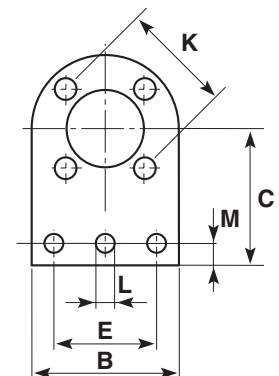

Flat gaskets

Size	A	B	gms	EPDM Code	FPM Code
16	27	2	2	23 431 305	23 432 305
20	32	2	2	23 431 306	23 432 306
25	38.5	2	3	23 431 307	23 432 307
32	44	2	4	23 431 308	23 432 308
40	59	2	4	23 431 309	23 432 309
50	71	2	5	23 431 310	23 432 310
63	88	2	10	23 431 311	23 432 311
75	104	2	20	23 431 312	23 432 312
90	123	2	30	23 431 313	23 432 313
110	148	3	40	23 431 314	23 432 314
160	211	3	60	23 431 317	23 432 317

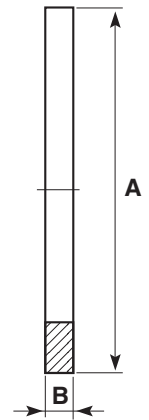

O-ring for socket union

Size	ID	B	gms	EPDM Code	FPM Code
16	15.54	2.62	23	23 209 305	23 211 305
20	20.22	3.53	39	23 209 306	23 211 306
25	28.17	3.53	68	23 209 307	23 211 307
32	32.93	3.53	94	23 209 308	23 211 308
40	40.65	5.34	163	23 209 309	23 211 309
50	47.00	5.34	190	23 209 310	23 211 310
63	59.69	5.34	355	23 209 311	23 211 311

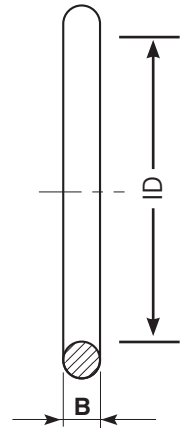

Cobra pipe clips

Size	A	B	C	D	G	Bolt/Screw	gms	Code
*12	-	24	25	15	16	M4/3BA/No 8	5	13 434 304
*16	-	35	25	17	16	M4/3BA/No 8	7	13 434 305
*20	-	35	30	14	16	M5/1BA/No 10	8	13 434 306
*25	-	35	35	16	17	M5/1BA/No 10	11	13 434 307
32	65	45	45	17	17	M5/1BA/No 10	14	13 434 308
40	75	65	65	20	20	M5/1BA/No 10	21	13 434 309
50	85	50	50	22	21	M6/OBA/No 10	30	13 434 310
63	102	60	60	19	21	M6/OBA/No 10	42	13 434 311
75	122	70	70	27	31	M8	94	13 434 312
90	148	80	90	39	31	M8	121	13 434 313
110	171	90	96	36	35	M8	184	13 434 314
160	238	170	150	44	40	M8	330	13 434 317

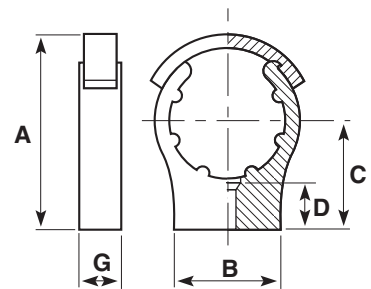

*Clips 32mm and above are fitted with a pipe retaining strap.
Bolts/screws not supplied.

Durapipe Corzan solvent cement and ECO cleaner

Litres	Code Durapipe Corzan cement	Code ECO cleaner
0.5	38 462 395	03 457 395
1.0	38 462 396	-

Only Durapipe Corzan solvent cement should be used for jointing the Durapipe Corzan system.

0.5 litre containers with integral applicators only suitable for use on sizes up to and including 63mm. For sizes above 63mm use 1 litre tins and brush.



Tools

Description	Product code
E 16-25mm pipe inner and outer milling cutter tool	FT 55 72 90
E 16-63mm pipe inner and outer milling cutter tool	FT 55 65 12
75-110mm chamfering tool	FT 55 05 10



Description	Product code
16-63mm pipe cutter	FT 80 00 01
50-125mm pipe cutter	FT 80 00 03
16-63mm spare cutter wheel	FT 80 00 02
50-125mm spare cutter wheel	FT 80 00 04



Pipe clips

Size mm	Product code
16	FT PC 1600
20	FT PC 2000
25	FT PC 2500
32	FT PC 3200
40	FT PC 4000
50	FT PC 5000
63	FT PC 6300
75	FT PC 7500
90	FT PC 9000



Brushes

Contents inch	Standard pack quantity in units	Product code
½" paint brush	1	03 254 102
1" paint brush	1	03 254 104
1½" paint brush	1	03 254 106
2" paint brush	1	03 254 107
3" paint brush	1	03 254 109
4" paint brush	1	03 254 110
3 pack paint brush set (1", 1½", 2")	1	03 254 001
5 pack paint brush set (½", 1", 1½", 2", 2½")	1	03 254 002
10 pack paint brush set (2x½", 3x1", 3x1½", 2x2")	1	03 254 003

VK Double union ball valve with metric series plain female ends for solvent welding

d	DN	PN	L	Z	H	E	B	C	gms	Code
16	10	16	14	75	103	55	49	66	218	HO VKK 305
20	15	16	16	71	103	55	49	66	212	HO VKK 306
25	20	16	19	77	115	66	59	75	335	HO VKK 307
32	25	16	22	84	128	75	66	85	445	HO VKK 308
40	32	16	26	94	146	87	75	97	695	HO VKK 309
50	40	16	31	102	164	100	87	110	950	HO VKK 310
63	50	16	38	123	199	121	101	134	1590	HO VKK 311
75	65	10	44	147	235	153	124	235	3170	HO VKK 312
90	80	10	51	168	270	188	142	285	5460	HO VKK 313
110	100	10	61	186	2308	220	166	335	8520	HO VKK 314

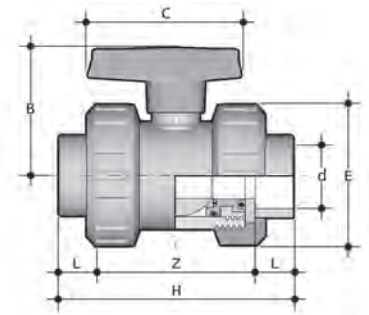

Codes given are for valves with FPM seals. Valves are also available with EPDM seals. Codes change by a single letter, thus in the example above: EPDM: HO VKJ 305.

SR Ball check valve with metric series male/female ends for solvent welding

d	DN	PN	E	L	Z	H	gms	Code
20	15	16	55	16	86	102	110	HO SRK 306
25	20	16	66	19	105	124	205	HO SRK 307
32	25	16	75	22	127	149	310	HO SRK 308
40	32	16	87	26	146	172	475	HO SRK 309
50	40	16	100	31	156	187	660	HO SRK 310
63	50	16	120	38	186	224	1120	HO SRK 311

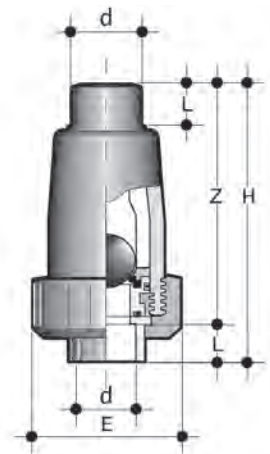

Codes given are for valves with FPM seals. Valves are also available with EPDM seals. Codes change by a single letter, thus in the example above: EPDM: HO SRJ 306.

VM Diaphragm valves with metric series male ends for solvent welding

d	DN	PN	B	B ₁	H	h	H ₁	I	J	L	gms	Code
20	15	10	95	26	124	12	90	25	M6	16	700	HO VMK 406
25	20	10	95	26	144	12	90	25	M6	19	700	HO VMK 407
32	25	10	95	26	154	12	90	25	M6	23	700	HO VMK 408
40	32	10	126	40	174	18	115	44.5	M8	27	1500	HO VMK 409
50	40	10	126	40	194	18	115	44.5	M8	32	1500	HO VMK 410
63	50	10	148	40	224	18	140	44.5	M8	39	2400	HO VMK 411
75	65	10	225	55	284	23	215	100	M12	44	7000	HO VMK 412
90	80	10	225	55	300	23	215	100	M12	51	7000	HO VMK 413
110	100	10	295	69	350	23	250	120	M12	-	10500	HO VMK 414

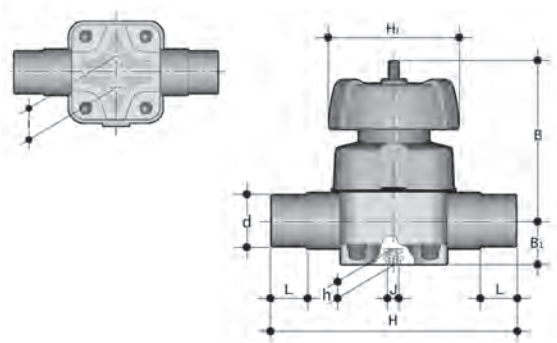

Codes given are for valves with FPM seals. Valves are also available with EPDM seals. Codes change by a single letter, thus in the example above: EPDM: HO VMJ 406.

FK Butterfly valve hand operated

d	DN	PN	B ₂	B ₃	C	C ₁	gms	U	Code
75	65	10	80	164	272	110	1470	4	HO FKK 108
90	80	10	93	178	272	110	1870	8	HO FKK 109
110	100	10	107	192	272	110	2220	8	HO FKK 110
160	150	10	134	225	330	110	3850	8	HO FKK 112

Codes given are for valves with FPM seals. Valves are also available with EPDM seals. Codes change by a single letter, thus in the example above: EPDM: HO FKJ 108.

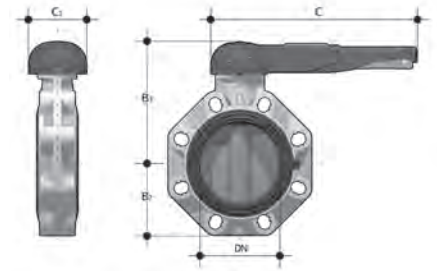

Pressure relief valve with plain male ends

d	Z	A	B	C	D	E	F	G	kg	Code
20	92	143	20.5	35	124	M6	25	12	0.7	HO PRK 406
25	106	143	20.5	35	144	M6	25	12	0.7	HO PRK 407
32	108	143	25	35	154	M6	25	12	0.7	HO PRK 408
40	120	204	36	50	174	M8	44.5	16	1.5	HO PRK 409
50	130	204	39.5	50	194	M8	44.5	16	1.5	HO PRK 410
63	146	219	49	50	224	M8	44.5	16	2.4	HO PRK 411

Codes given are for valves with FPM seals. Valves are also available with EPDM seals. Codes change by a single letter, thus in the example above: EPDM: HO PRJ 406.

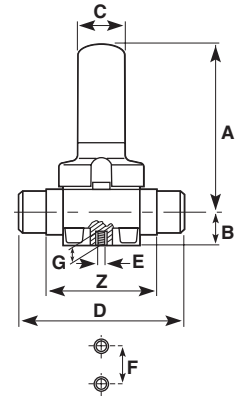

RV Sediment strainer manual – FPM seals

d	DN	A max	B	E	L	Z	H	g	Code
20	15	125	72	55	16	103	135	211	HO UVK 305
25	20	145	84	66	19	120	158	358	HO UVK 306
32	25	165	95	75	22	132	176	526	HO UVK 307
40	32	190	111	87	26	155	207	733	HO UVK 308
50	40	210	120	100	31	181	243	1095	HO UVK 309
63	50	240	139	120	38	222	298	1843	HO UVK 310

Codes given are for valves with FPM seals. Valves are also available with EPDM seals. Codes change by a single letter, thus in the example above: EPDM: HO UVJ 305.

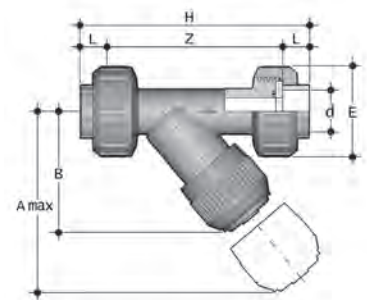

TK-PVC-C 3-way T Port Ball Valve with metric series plain female ends for solvent welding

d	DN	C	C ₁	C ₂	B	B ₁	B ₂	PN	E	H	H ₁	L	Z	g	Code
16	10	83.5	29.5	54	87.5	33	50	16	55	118	80	14	90	380	HO TKK 305
20	15	83.5	29.5	54	87.5	33	50	16	55	118	80	16	86	380	HO TKK 306
25	20	98	35.5	62.5	98.5	39	56.5	16	66	145	100	19	107	650	HO TKK 307
32	25	105	37	68	106	45	61.5	16	75	160	110	22	116	932	HO TKK 308
40	32	139.5	51	88.5	135	52	76.5	16	87	188.5	131	26	136.5	1455	HO TKK 309
50	40	139.5	51	88.5	139	57	80.5	16	100	219	148	31	157	1890	HO TKK 310
63	50	154	51	103	159	69	97.5	16	122	266.5	179	38	190.5	3200	HO TKK 311

For L Port order HO LKK 305, inserting the dimension size required.

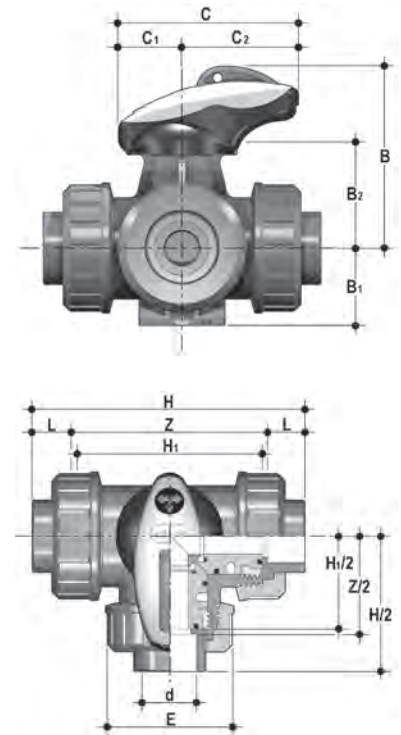

Actuated valves

Durapipe UK offers a comprehensive range of actuated valves with either pneumatic or electric actuators, to meet the demands of the wide range of applications found in industrial pipework installations.

- Design and valve/actuator sizing advice
- On site training and service
- Full Quality Assurance ability to EN ISO 9001:2000
- Technical advice from Durapipe UK Technical Support – telephones manned throughout the working day
- Every valve traceable from its individual serial number

The following actuated valves, compatible with the Durapipe Corzan systems, are available:

- VK Ball Valve – electrically and pneumatically actuated
- VM Diaphragm – pneumatically actuated
- FK Butterfly – electrically and pneumatically actuated

Further details are given in Price Lists D0299, D0897 and in Valve Technical brochure D0894.

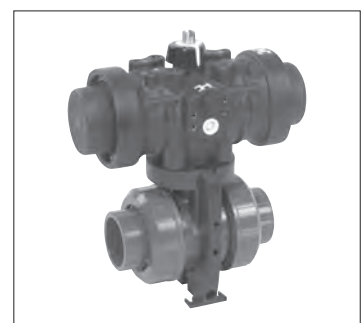

Other Durapipe UK systems

ABS

- Ideal for chilled, potable and waste water
- Tough, durable, lightweight and fully approved
- Suitable for use from -40°C to +70°C
- Fully matched system of pipes, fittings and valves.



Polypropylene

- Thermoplastic pipe heat-weld system to convey chemicals at temperatures up to 100°C
- Excellent resistance to a wide range of substances
- Available in larger diameters up to 500mm
- Full range of valves.



PVC-U

- Versatile, general purpose solvent weld pipework system with an extensive range of valves and fittings. The established system for process and industrial handling of chemicals and water up to 60°C.



Air-Line Xtra

- High performance thermoplastic pipework system for compressed air.



Friatherm

- A better way for hot and cold water offering quick, easy and efficient installations.



Vulcathene

- Safe chemical drainage
- Two easy jointing methods - Mechanical or Enfusion
- Ideal for schools, universities and colleges, hospitals and clinics, pharmaceutical and research organisations.



Durapipe UK reserves the right to modify the details in this publication as products and specifications are updated and improved. The content of this publication is for general information only and it is the user's responsibility to determine the suitability of any product for the purpose intended.

For further information on all Durapipe UK products and services contact our Customer Services Department as detailed below.

Customer Services

Tel: +44 (0)844 800 5509

Fax: +44 (0)1543 471682

Durapipe UK is a trade name of Glynwed Pipe Systems Ltd. Company Number 1698059.

Registered office:

Durapipe UK

Hyssop Close

Swaffield Park

Cannock

Staffordshire

WS11 7FU

United Kingdom

Tel: +44 (0)1543 471680

Fax: +44 (0)1543 471682

email: enquiries@durapipe.co.uk

web: www.durapipe.co.uk

Twitter: @DurapipeUK

Distributor

D0414 August 2018